

Installation Manual

SMA SPEEDWIRE/WEBCONNECT DATA MODULE

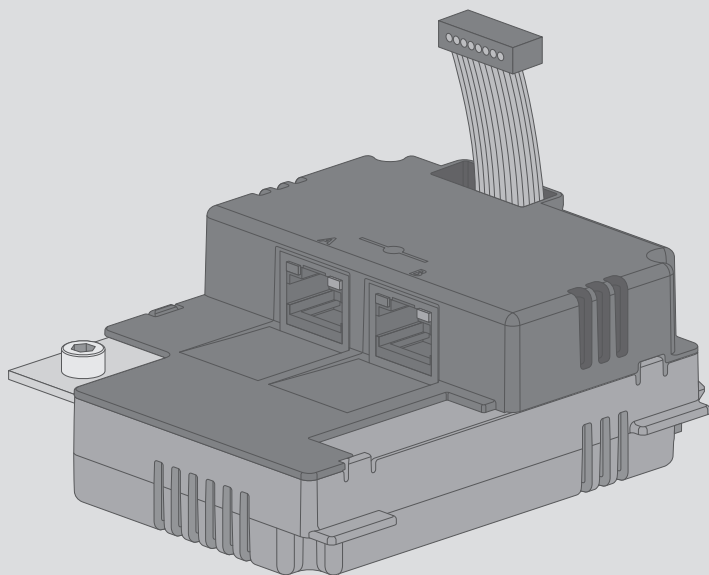

Legal Provisions

The information contained in these documents is property of SMA Solar Technology AG. Any publication, whether in whole or in part, requires prior written approval by SMA Solar Technology AG. Internal reproduction used solely for the purpose of product evaluation or other proper use is allowed and does not require prior approval.

SMA Warranty

You can download the current warranty conditions from the Internet at www.SMA-Solar.com.

Trademarks

All trademarks are recognized, even if not explicitly identified as such. Missing designations do not mean that a product or brand is not a registered trademark.

Modbus[®] is a registered trademark of Schneider Electric and is licensed by the Modbus Organization, Inc.

QR Code is a registered trademark of DENSO WAVE INCORPORATED.

Phillips[®] and Pozidriv[®] are registered trademarks of Phillips Screw Company.

Torx[®] is a registered trademark of Acument Global Technologies, Inc.

SMA Solar Technology AG

Sonnenallee 1

34266 Niestetal

Germany

Tel. +49 561 9522-0

Fax +49 561 9522-100

www.SMA.de

Email: info@SMA.de

Copyright © 2016 SMA Solar Technology AG. All rights reserved.

Table of Contents

1	Information on this Document	5
1.1	Validity	5
1.2	Target group	5
1.3	Additional Information.....	5
1.4	Symbols.....	5
1.5	Typographies	6
1.6	Nomenclature	6
1.7	Figures	6
2	Safety	7
2.1	Intended Use.....	7
2.2	Safety Information	7
2.3	Operating Instructions	8
2.4	Supported Products	9
3	Scope of Delivery	10
4	Product Description	11
4.1	Speedwire/Webconnect Data Module.....	11
4.2	Information on Webconnect/Cluster Controller systems in Sunny Portal	12
4.3	Possible Network Topologies	13
4.4	Type Label.....	13
4.5	Cable Gland.....	14
5	Connection	15
5.1	Mounting Position and Cable Route	15
5.2	Cable Requirements	15
5.3	Installing the Speedwire/Webconnect Data Module.....	16
5.4	Connecting the Speedwire/Webconnect Data Module	17
6	Commissioning	20
6.1	Commissioning the Cluster Controller System	20
6.2	Commissioning the Webconnect System	20

6.3	Managing Webconnect Systems with Sunny Explorer	21
6.3.1	Functions and Parameter Settings in Sunny Explorer	21
6.3.2	Connecting the Webconnect System to Sunny Explorer.....	21
6.4	Configuring the Modbus Function	22
6.5	PV System Registration in Sunny Portal	23
6.5.1	Registering the Webconnect System in Sunny Portal.....	23
6.5.2	Registering the Cluster Controller System in Sunny Portal	23
7	Troubleshooting.....	25
8	Decommissioning	27
8.1	Removing the Speedwire/Webconnect Data Module	27
8.2	Packing the Product for Shipment.....	28
8.3	Disposing of the Product	28
9	Technical Data	29
10	Contact	30

1 Information on this Document

1.1 Validity

This document is valid for device type "SWDM-10.GR1" (Speedwire/Webconnect data module) from hardware version A and firmware version 1.00.20.R.

1.2 Target group

The tasks described in this document must only be performed by qualified persons. Qualified persons must have the following skills:





- Knowledge of how an inverter works and is operated
- Training in how to deal with the dangers and risks associated with installing and using electrical devices and installations
- Training in the installation and configuration of IT systems
- Training in the installation and commissioning of electrical devices and installations
- Knowledge of the applicable standards and directives
- Knowledge of and compliance with this document and all safety information

1.3 Additional Information

Links to additional information can be found at www.SMA-Solar.com:

Document title	Document type
"Firmware Update with SD Card"	Technical Description
"SMA SPEEDWIRE FIELDBUS"	Technical Information
"SMA Modbus® Interface"	Technical Description
"SunSpec® Modbus® Interface"	Technical Description

1.4 Symbols

Symbol	Explanation
 DANGER	Indicates a hazardous situation which, if not avoided, will result in death or serious injury
 WARNING	Indicates a hazardous situation which, if not avoided, can result in death or serious injury
 CAUTION	Indicates a hazardous situation which, if not avoided, can result in minor or moderate injury
NOTICE	Indicates a situation which, if not avoided, can result in property damage
	Information that is important for a specific topic or goal, but is not safety-relevant

Symbol	Explanation
□	Indicates a requirement for meeting a specific goal
☑	Desired result
✘	A problem that might occur

1.5 Typographies

Typography	Use	Example
bold	<ul style="list-style-type: none"> • Display texts • Elements on a user interface • Terminals • Elements to be selected • Elements to be entered 	<ul style="list-style-type: none"> • The value can be found in the field Energy. • Select Settings. • Enter 10 in the field Minutes.
>	<ul style="list-style-type: none"> • Connects several elements to be selected 	<ul style="list-style-type: none"> • Select Settings > Date.
[Button] [Key]	<ul style="list-style-type: none"> • Button or key to be selected or pressed 	<ul style="list-style-type: none"> • Select [Next].

1.6 Nomenclature

Complete designation	Designation in this document
SMA Cluster Controller	Cluster Controller
SMA Speedwire	Speedwire
SMA Speedwire/Webconnect Data Module	Speedwire/Webconnect data module
SMA Webconnect function	Webconnect function
SMA inverter	Inverter

1.7 Figures

The figures in this document have been created for Sunny Boy inverters and may deviate slightly in some cases for Sunny Tripower inverters.

2 Safety

2.1 Intended Use

The Speedwire/Webconnect data module is a Speedwire communication interface with Webconnect function for one inverter.

The inverter still complies with the standard after the product has been installed.

Use this product only in accordance with the information provided in the enclosed documentation and with the locally applicable standards and directives. Any other application may cause personal injury or property damage.

Alterations to the product, e.g. changes or modifications, are only permitted with the express written permission of SMA Solar Technology AG. Unauthorized alterations will void guarantee and warranty claims and in most cases terminate the operating license. SMA Solar Technology AG shall not be held liable for any damage caused by such changes.

Any use of the product other than that described in the Intended Use section does not qualify as appropriate.

The enclosed documentation is an integral part of this product. Keep the documentation in a convenient place for future reference and observe all instructions contained therein.

2.2 Safety Information

This section contains safety information that must be observed at all times when working on or with the product.

To prevent personal injury and property damage and to ensure long-term operation of the product, read this section carefully and observe all safety information at all times.

DANGER

Danger to life due to electric shock when opening the inverter

High voltages are present in the conductive components of the inverter. Touching live components results in death or serious injury.

- Prior to performing any work on the inverter, always disconnect the inverter from voltage sources on the AC and DC sides and secure it against reconnection (see the inverter manual). Observe the waiting time to allow the capacitors to discharge.

CAUTION

Risk of burns due to hot enclosure parts

Some parts of the enclosure can get hot during operation.

- Do not touch any parts other than the lower enclosure lid of the inverter during operation.

NOTICE**Damage to the inverter or product due to electrostatic discharge**

Touching electronic components can cause damage to or destroy the inverter or the product through electrostatic discharge.

- Ground yourself before touching any component.

2.3 Operating Instructions

NOTICE**High costs possible due to inappropriate Internet tariff**

When using the Webconnect function, a constant Internet connection is required.

Depending on the quality of the Internet connection, the data transfer volume for an inverter is between 150 MB and 550 MB per month. When using the system overview in Sunny Portal with live data display, there is an additional data volume of 600 kB per hour.

- SMA Solar Technology AG recommends using an Internet flat rate.

i If UMTS is used, VoIP is required

If UMTS is used, VoIP (Voice over IP) is required to use the Webconnect function.

- Ensure that the UMTS provider also provides the VoIP service.

Observe router configuration

When using routers or network switches with router function, make sure that Speedwire uses addresses from the Multicast area 239/8 besides directly communicating with individual IP nodes. The Multicast address group 239/8 (239.0.0.0 to 239.255.255.255) is defined by RFC 2365 as a locally managed address space with local and regional expansion or throughout the organization.

Make sure that the routers and network switches in your Speedwire network forward the Multicast telegrams (telegrams with destination address 239.0.0.0 to 239.255.255.255) required for the Speedwire connection to all nodes of the Speedwire network (for information on configuration of the router or network switch, see the manufacturer's manual).

IGMP protocol from version 2 must be supported

Ensure that multicasts are used when connecting the SMA Energy Meter to the Speedwire/ Webconnect data module. For the correct function of the SMA Energy Meter, all network devices used must support the IGMP protocol, minimum required version 2 (IGMP V2).

2.4 Supported Products

SMA Inverters

The Speedwire/Webconnect data module must only be installed in the following SMA inverters from the indicated inverter firmware version:

SMA Inverters*	From inverter firmware version
SB 2500TLST-21	2.53
SB 3000TLST-21	
SB 3000TL-21	2.53
SB 3600TL-21	
SB 4000TL-21	
SB 5000TL-21	
SB 6000TL-21	
STP 8000TL-10	
STP 10000TL-10	
STP 12000TL-10	
STP 15000TL-10	
STP 17000TL-10	
STP 15000TLEE-10	2.53
STP 15000TLHE-10	
STP 15000TL-30	All
STP 20000TL-30	
STP 25000TL-30	
STP 20000TLEE-10	2.53
STP 20000TLHE-10	

* For information on which of these SMA inverters with Speedwire/Webconnect data module supports the Modbus interface of the Speedwire/Webconnect data module, see the Datasheet "SMA_Modbus-DB-en.xlsx" at www.SMA-Solar.com.

If the firmware version of the inverter is lower than specified, you must update the inverter firmware to the version indicated or higher. For information on performing the firmware update, refer to the Technical Description "Firmware Update with SD Card" at www.SMA-Solar.com.

Additional SMA Products

The Speedwire/Webconnect data module can be configured with the following communication products:

- SMA Cluster Controller from firmware version 1.0
- Sunny Explorer from software version 1.06
- SMA Connection Assist from software version 1.00.8.R

Sunny Explorer and SMA Connection Assist are available free of charge at www.SMA-Solar.com.

3 Scope of Delivery

Check the scope of delivery for completeness and any externally visible damage. Contact your distributor if the scope of delivery is incomplete or damaged.

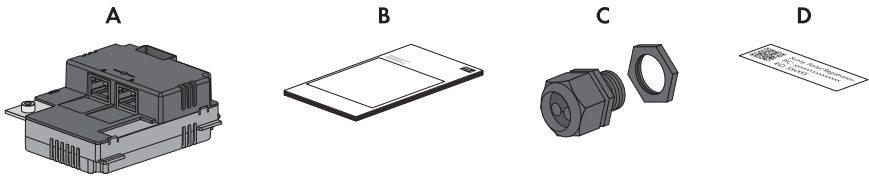

Figure 1: Components included in the scope of delivery

Position	Quantity	Designation
A	1	Speedwire/Webconnect data module (SWDM-10)*
B	1	Installation Manual
C	1	M32 cable gland with sealing plug, two-hole cable support sleeve and counter nut
D	2	Labels with PIC and RID for registration of a Webconnect system in Sunny Portal

* This component is not included if the Speedwire/Webconnect data module is installed upon delivery.

4 Product Description

4.1 Speedwire/Webconnect Data Module

The Speedwire/Webconnect data module is a Speedwire communication interface with Webconnect function for one inverter.

Speedwire uses the internationally established Ethernet standard, the Ethernet based IP protocol as well as the communication protocol SMA Data2+ optimized for PV systems. This enables a consistent 10/100 Mbit data transmission to the inverter as well as reliable monitoring, control, and regulation of the PV system.

The Webconnect function enables direct data transmission between the inverters of a Webconnect system and the Internet portal Sunny Portal without any additional communication device and for a maximum of 4 inverters per Sunny Portal system. You can access your Sunny Portal system from any computer with an Internet connection. In Cluster Controller systems, data transmission to the Internet portal Sunny Portal is carried out via the Cluster Controller.

The Speedwire/Webconnect data module performs the following tasks:

- Set-up of a Speedwire network
 - In Webconnect systems for the inverter communication with Sunny Explorer
 - In Cluster Controller systems for inverter communication with the Cluster Controller
- Data exchange in a Cluster Controller system via a router/network switch
- Data exchange with Sunny Portal:
 - In Webconnect systems via a router with Internet connection
 - In Cluster Controller systems via the Cluster Controller
- Data exchange with Sunny Explorer
- Additionally for PV systems in Italy: Connection to or disconnection of the inverter from the utility grid and definition of the frequency limits to be used by means of IEC61850-GOOSE messages
- The Modbus interface of the Speedwire/Webconnect data module is designed for industrial use and has the following tasks:
 - Remote query of measured values
 - Remote setting of parameters
 - Setpoint specifications for system control

Support of Modbus interface

For information on which of the supported SMA inverters (see Section 2.4, page 9) support the Modbus interface of the Speedwire/Webconnect data module, refer to the Datasheet "SMA_Modbus-DB-en.xlsx" at www.SMA-Solar.com.

Design of the Speedwire/Webconnect data module

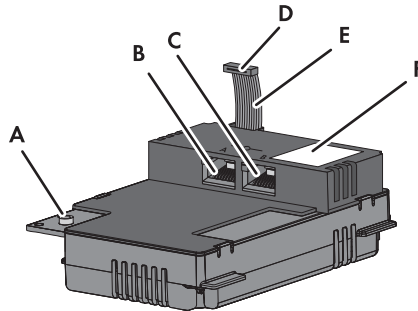

Figure 2: Design of the Speedwire/Webconnect data module

Position	Designation
A	Hexagon socket screw
B	Network port A
C	Network port B
D	Ribbon cable plug
E	Ribbon Cable
F	Type label

4.2 Information on Webconnect/Cluster Controller systems in Sunny Portal

Each inverter can only be used in one Sunny Portal system

Each inverter can only be used in one Sunny Portal system. It is not possible to register an inverter, for example, via Sunny WebBox with BLUETOOTH and via the Webconnect function in Sunny Portal and to use the inverter in two Sunny Portal systems.

In Cluster Controller systems, at maximum one Cluster Controller forms a Sunny Portal system

A Cluster Controller system can only consist of one Cluster Controller in Sunny Portal. If you use several Cluster Controllers, you must create a separate Sunny Portal system for each Cluster Controller.

Data exchange with Sunny Portal is carried out via the Cluster Controller which is connected to a router with Internet connection.

Maximum number of inverters in Webconnect systems in Sunny Portal

A Webconnect system in Sunny Portal can comprise a maximum of 4 inverters with an integrated Speedwire/Webconnect data module. If you use more inverters with Speedwire/Webconnect data module in your system, you must create further Sunny Portal systems.

Data exchange with Sunny Portal is carried out via the individual inverters connected to a router with Internet connection.

Cluster Controller system and/or Webconnect system cannot be combined with other Sunny Portal systems

Even if you already have a PV system registered in Sunny Portal with another communication device, e.g. Cluster Controller, Sunny WebBox, Sunny Home Manager or Sunny Multigate, you will still need to create a separate Sunny Portal system for your Cluster Controller system and your Webconnect system.

Labels with PIC and RID for registration of a Webconnect system in Sunny Portal

For activating the Speedwire/Webconnect data module of a Webconnect system in Sunny Portal, you need the PIC (Product Identification Code, identification key for registration in Sunny Portal) and RID (Registration Identifier, registration ID for registration in Sunny Portal) which you will find on the supplied label. After installation of the Speedwire/Webconnect data module, a label should be attached to the exterior of the inverter in the vicinity of the type label. Keep the other label in a safe place for future reference.

4.3 Possible Network Topologies

The possible network topologies depend on the devices used and on the number of network ports. The Speedwire/Webconnect data module has two network ports. For further information on network topologies, refer to the Technical Information "SMA SPEEDWIRE FIELDBUS".

4.4 Type Label



The type label clearly identifies the product. The type label is located in the right-hand top corner on the front of the product. You can read off the following data from the type label:

- Device type (Type)
- Serial number (Serial No.)
- Hardware version (Version)
- PIC
- RID
- MAC Address

You will require the information on the type label to use the product safely and when seeking customer support from Service (see Section 10 "Contact", page 30).

Symbols on the Type Label

Symbol	Designation	Explanation
	CE marking	The product complies with the requirements of the applicable EU directives.

Symbol	Designation	Explanation
 N23114	C-Tick	The product complies with the requirements of the applicable Australian EMC standards.
	Data matrix code	2D code for device-specific characteristics

4.5 Cable Gland

The cable gland provides a sturdy, tightly sealed connection of the network cables with the inverter enclosure. The cable gland also protects the interior of the inverter from dust intrusion and moisture penetration.

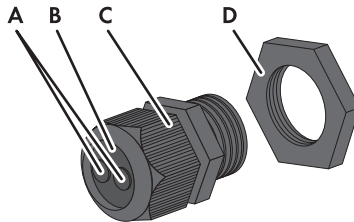

Figure 3: Components of the cable gland

Position	Designation
A	Filler plug
B	Seal
C	Swivel nut
D	Counter nut

5 Connection

5.1 Mounting Position and Cable Route

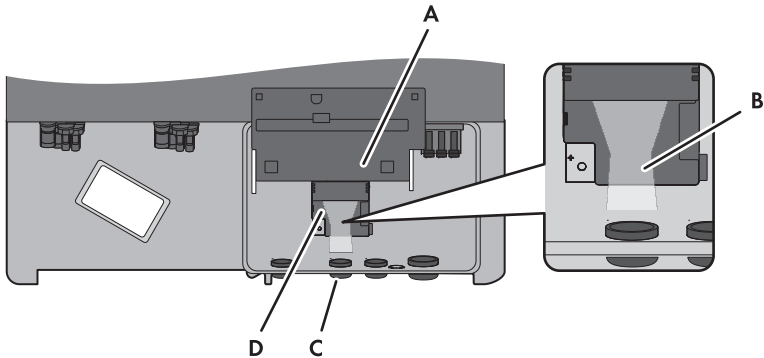

Figure 4: Mounting position and cable route in the inverter with the lower enclosure lid open and the display flipped up

Position	Designation
A	Flipped up display
B	Cable route to the network ports of the Speedwire/Webconnect data module
C	Enclosure opening with filler plugs for the network cables <ul style="list-style-type: none"> • Diameter of the opening for Sunny Boy inverters (SB): 19 mm ($\frac{3}{4}$ in) • Diameter of the opening for Sunny Tripower inverters (STP): 27.8 mm ($1\frac{3}{32}$ in) to 28 mm ($1\frac{7}{64}$ in)
D	Mounting position of the Speedwire/Webconnect data module

5.2 Cable Requirements

The cable length and cable quality affect the signal strength in the Speedwire network. Observe the following cable requirements and the information on cable laying.

i Interference in data transmission due to unshielded power cables

If unshielded power cables are used, they generate an electromagnetic field during operation which may induce interference in network cables during data transmission.

- When laying network cables, observe the following minimum clearances to unshielded energy cables:
 - For installation without separating strip: at least 200 mm
 - For installation with aluminum separating strip: at least 100 mm
 - For installation with steel separating strip: at least 50 mm

- External diameter of the cable:

When using conduits:

The maximum external diameter of the cable depends on the size of the opening used for the network cables and on the number of inserted network cables. Size of the openings, see (see Section 5.1, page 15).

When using the supplied cable gland: max. 9 mm

5.3 Installing the Speedwire/Webconnect Data Module

1. DANGER

Danger to life due to electric shock when opening the inverter

High voltages are present in the conductive components of the inverter. Touching live components results in death or serious injury.

- Disconnect the inverter from all voltage sources on the AC and DC sides and open it (see the inverter manual). Observe the waiting time to allow the capacitors to discharge.

2. Loosen the screw of the display and flip the display up until it snaps into place.

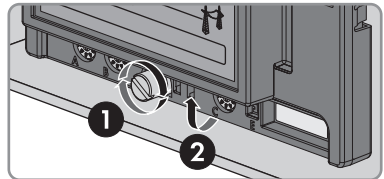

3. Insert the Speedwire/Webconnect data module and slide the ribbon cable upwards behind the display. The key on the right-hand back corner of the Speedwire/Webconnect data module must fit into the hole in the plastic retainer in the inverter.

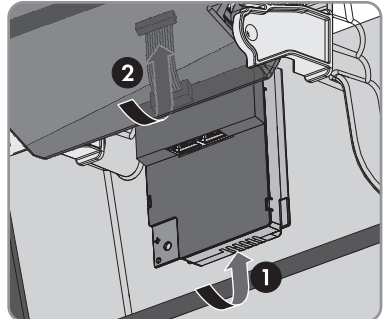

4. Tighten the screw on the Speedwire/Webconnect data module with an Allen key (AF: 3) in such a way that it can withstand a torque of 1.5 Nm.

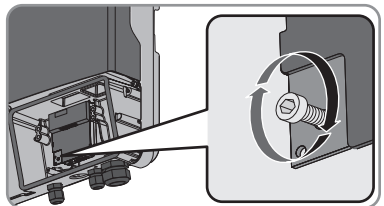

5. Flip the display down.

6. Plug the ribbon cable plug onto the center connector strip in the inverter. The lateral lock hooks clasp the plug.

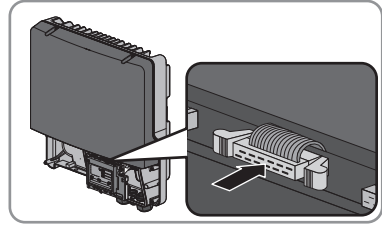

7. Stick one of the labels with the data for registration in Sunny Portal (PIC and RID) on the outside of the inverter in the vicinity of the type label.

5.4 Connecting the Speedwire/Webconnect Data Module

Depending on the system topology, you must connect either one or two cables to the Speedwire/Webconnect data module.

Requirement:

- The network cables must be preassembled in accordance with the system topology and the cable requirements (see Section 5.2, page 15).

Additionally required material (not included in the scope of delivery):

- Network cables (see Section 5.2 "Cable Requirements", page 15)

Procedure:

1. **⚠ DANGER**

Danger to life due to electric shock when opening the inverter

High voltages are present in the conductive components of the inverter. Touching live components results in death or serious injury.

- Disconnect the inverter from all voltage sources on the AC and DC sides and open it (see the inverter manual). Observe the waiting time to allow the capacitors to discharge.

2. Loosen the screw of the display and flip the display up until it snaps into place.

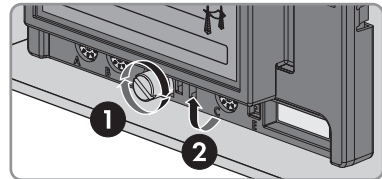

3. Push the filler plug from the inside out of the second hole from the left in the inverter enclosure and retain it for future decommissioning.

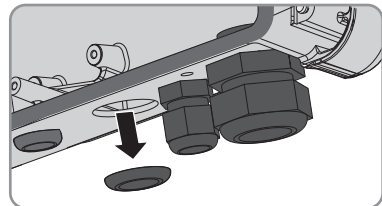

4. Unscrew the counter nut from the cable gland.

5. Screw the cable gland with the counter nut on the inverter enclosure opening.

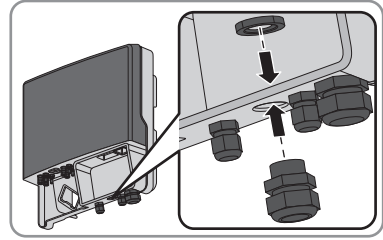

6. Unscrew the swivel nut from the cable gland.

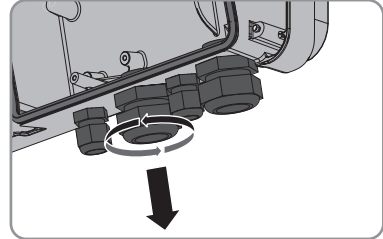

7. Press the seal out of the cable gland from the inside.

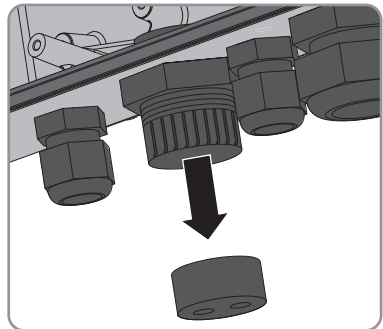

8. For each network cable, remove one of the filler plugs from the seal and retain it for later decommissioning.

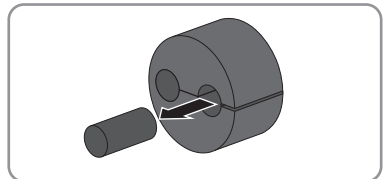

9. Lead one or both network cables through the swivel nut and into the seal. Route the network cable plugs into the inverter to the network ports of the Speedwire/Webconnect data module.

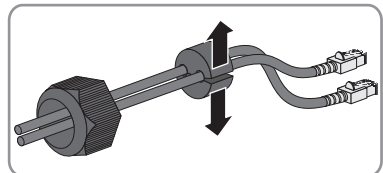

10. Press the seal into the cable gland. Ensure that any unused cable openings are sealed with filler plugs.
 11. Screw the swivel nut of the cable gland on loosely.

12. Insert the network cables into the network ports of the Speedwire/Webconnect data module. This can be done in any order.
13. Fasten the swivel nut on the cable gland hand-tight. This will secure the network cables in place.
14. Flip the display down and fasten the screw of the display hand-tight.
15. Close the inverter (see the inverter manual).
16. In a Webconnect system, connect the network cables to an inverter or router/network switch in accordance with the network topology. Connect at least one inverter to the router either directly or via a network switch in accordance with the network topology.
17. In a Cluster Controller system, connect the Cluster Controller and the inverters to the Speedwire network in accordance with the required network topology (see the Cluster Controller installation manual).

6 Commissioning

6.1 Commissioning the Cluster Controller System

Requirements:

- Speedwire/Webconnect data modules must be installed (see Section 5.3, page 16).
- Speedwire/Webconnect data modules must be connected (see Section 5.4, page 17).
- The Cluster Controller must be connected to the Speedwire network in accordance with the desired network topology (see installation manual of the Cluster Controller).

Procedure:

1. Commission all inverters (see inverter manual).
2. For optimum operation of Cluster Controller systems, deactivate the Webconnect function of the inverters with installed Speedwire/Webconnect data module (see user manual of the Cluster Controller). In Cluster Controller systems, communication with Sunny Portal takes place via the Cluster Controller itself.

6.2 Commissioning the Webconnect System

Requirements:

- Speedwire/Webconnect data modules must be installed (see Section 5.3, page 16).
- Speedwire/Webconnect data modules must be connected (see Section 5.4, page 17).
- There must be a router with Internet connection in the local network of the system.
- At least one inverter must be connected to the router.
- If the IP addresses in the local network are to be assigned dynamically, DHCP must be activated in the router (see the router manual). If you do not want to use DHCP or your router does not support DHCP, use either SMA Connection Assist or Sunny Explorer to integrate the inverters with the Speedwire/Webconnect data module into your network (see Section 2.4, page 9).
- For PV systems in Italy: In order to adjust the Sunny Explorer settings for Italy regarding the reception of control signals from the Speedwire/Webconnect data module, you must have a personal SMA Grid Guard code (see Sunny Explorer help).

Procedure:

1. Commission all inverters (see inverter manual).
2. For PV systems in Italy, in order to activate reception of control signals from the grid operator in the Speedwire/Webconnect data module, carry out the following steps:
 - Connect with Sunny Explorer (see Section 6.3.2, page 21).
 - Enter your personal SMA Grid Guard code in Sunny Explorer (see Sunny Explorer help).

- Set the following parameters in Sunny Explorer (for setting parameters in a device, see Sunny Explorer help):

External communication > IEC 61850 configuration			
Parameter	Value/range	Resolution	Default
Application ID	0 ... 16384	1	16384
GOOSE-Mac address	01:0C:CD:01:00:00 ... 01:0C:CD:01:02:00	1	01:0C:CD:01:00:00

- In the field **Application ID**, enter the application ID of the grid operator gateway. You will receive this value from your grid operator. You can enter a value between **0** and **16384**. The value **16384** indicates "deactivated".
- In the field **GOOSE-Mac address**, enter the MAC address of the grid operator gateway from which the Speedwire/Webconnect data module is to receive the control commands. You will receive this value from your grid operator.
 - The receipt of control signals from the grid operator is activated.

6.3 Managing Webconnect Systems with Sunny Explorer

6.3.1 Functions and Parameter Settings in Sunny Explorer

The following functions for PV system management are available in Sunny Explorer:

- Overview of the PV system status
- Graphic display of key PV system data, device data and energy values
- Parameterization of individual devices or entire device classes
- Simple diagnostics thanks to display of errors and events
- Data export of inverter energy values and events in CSV format
- Device updates

You can change the following parameters in Sunny Explorer:

- Inverter name
- Automatic IP configuration On/Off
- DNS-IP, gateway IP, IP address, subnet mask
- Webconnect function On/Off
- IEC 61850 configuration for PV systems in Italy up to 6 kW

6.3.2 Connecting the Webconnect System to Sunny Explorer

Sunny Explorer establishes a connection to the inverters via Speedwire communication.

Requirements:

- The Webconnect system must be commissioned (see Section 6.2, page 20).

- Sunny Explorer must be installed on the computer (see Section 2.4, page 9).

Procedure:

1. Connect the computer to the router/network switch of the system with a network cable.
2. If you have used SMA Connection Assist for the static network configuration, ensure that SMA Connection Assist has ended.
3. Start Sunny Explorer and create a Speedwire system in Sunny Explorer (see Sunny Explorer help).

6.4 Configuring the Modbus Function

QUALIFIED PERSON

The Modbus interface is deactivated by default and the communication ports **502** set. In order to access SMA inverters with SMA Modbus® or SunSpec® Modbus®, the Modbus interface must be activated. After activating the interface, the communication ports of both IP protocols can be changed.

For information on commissioning and configuration of the Modbus interface, see the Technical Information "SMA Modbus® Interface" or in the Technical Information "SunSpec® Modbus® Interface" at www.SMA-Solar.com.

For information on which of the supported SMA inverters (see Section 2.4, page 9) support the Modbus interface of the Speedwire/Webconnect data module, refer to the Datasheet "SMA_Modbus-DB-en.xlsx" at www.SMA-Solar.com.

Data security during activated Modbus interface

If you activate the Modbus interface, there is a risk that unauthorized users may access and manipulate the data or devices in your PV system.

- Take appropriate protective measures such as:
 - Set up a firewall.
 - Close unnecessary network ports.
 - Only enable remote access via VPN tunnel.
 - Do not set up port forwarding at the communication port in use.
 - In order to deactivate the Modbus interface, reset the inverter to default settings.

Procedure:

- Activate the Modbus interface and adjust the communication ports if necessary (see the Technical Information "SMA Modbus® Interface" or "SunSpec® Modbus® Interface" at www.SMA-Solar.com).

6.5 PV System Registration in Sunny Portal

6.5.1 Registering the Webconnect System in Sunny Portal

i Information on Webconnect/Cluster Controller systems in Sunny Portal

Note the information on Webconnect/Cluster Controller systems in Sunny Portal (see Section 4.2, page 12).

Requirements:

- The Webconnect system must be commissioned (see Section 6.2, page 20).
- PIC and RID of the Speedwire/Webconnect data module must be available.
- Your computer must have an Internet connection.
- JavaScript must be enabled in the web browser.
- All UDP ports greater than 1024 on the router must be open for outgoing connections. If there is a firewall installed on the router, you might have to adjust the firewall settings.
- It must be possible for the outgoing router connections to reach all Internet destinations (target IP, target port). If there is a firewall installed on the router, you might have to adjust the firewall settings.
- On the router with NAT (Network Address Translation), no port forwarding must be entered. Potential communication problems can thus be prevented.
- There must be no packet filtering or manipulation for SIP packets installed on the router.

i Replacing the Speedwire/Webconnect data module in the inverter

If you have replaced the Speedwire/Webconnect data module in the inverter with a new Speedwire/Webconnect data module, the PIC and the RID of the inverter change. In this case, you must replace the inverter using the PV System Setup Assistant in Sunny Portal (see the Sunny Portal user manual). In the PV System Setup Assistant, you must enter the PIC and the RID of the new Speedwire/Webconnect data module.

Starting the PV System Setup Assistant in Sunny Portal

The PV System Setup Assistant is a step-by-step guide to the processes required for user registration and the registration of your system in Sunny Portal

Procedure:

1. Go to www.SunnyPortal.com.
2. Select [PV System Setup Assistant].
 - The PV System Setup Assistant opens.
3. Follow the instructions of the PV System Setup Assistant.

6.5.2 Registering the Cluster Controller System in Sunny Portal

Requirements:

- The Cluster Controller system must be commissioned (see Section 6.1, page 20).

- Your computer must have an Internet connection.
- The Cluster Controller must be connected to a router with Internet connection (see installation manual of the Cluster Controller).
- JavaScript must be enabled in the web browser.

Procedure:

- In Cluster Controller systems, register in Sunny Portal via the user interface of the Cluster Controller (see user manual of the Cluster Controller).

7 Troubleshooting

i Corrective measures regarding Modbus errors

Corrective measures regarding Modbus errors can be found in the Technical Descriptions "SMA Modbus® Interface" and "SunSpec® Modbus® Interface".

Problem	Cause and corrective measure
<p>The Speedwire/Webconnect data module cannot be accessed.</p>	<p>There is no Speedwire connection.</p> <p>Corrective measures:</p> <ul style="list-style-type: none"> • Ensure that all network cable plugs are inserted and locked. • Ensure that all inverters in the PV system are in operation. • Ensure that the system router is switched on. • Ensure that the ribbon cable plug of the Speedwire/Webconnect data module is correctly plugged into the center connector strip in the inverter.
	<p>The Speedwire/Webconnect data module does not have a valid IP address.</p> <p>Corrective measures:</p> <ul style="list-style-type: none"> • Ensure that DHCP is enabled for the router. <p>or</p> <p>Assign an appropriate static IP address to the Speedwire/Webconnect data module via SMA Connection Assist or Sunny Explorer. You can obtain the SMA Connection Assist software and the Sunny Explorer free of charge from the download area at www.SMA-Solar.com.</p>
	<p>The firewall is not set correctly.</p> <p>Corrective measures:</p> <ul style="list-style-type: none"> • Enable ports 3478 and 9523 in the firewall (see firewall manual).

Problem	Cause and corrective measure
The Speedwire/Webconnect data module cannot be accessed.	<p>The UDP ports in the router for outgoing connections are not open.</p> <p>Corrective measures:</p> <ul style="list-style-type: none"> • Open the UDP ports greater than 1024 in the router for outgoing connections. <hr/> <p>The IP filter is not configured correctly.</p> <p>Corrective measures:</p> <ul style="list-style-type: none"> • Adjust the IP filter settings (see router manual). <hr/> <p>There is a packet filter or SIP packet manipulation installed on the router.</p> <p>Corrective measures:</p> <ul style="list-style-type: none"> • Uninstall the packet filtering for SIP packets or the manipulation for SIP packets on the router.
The Speedwire/Webconnect data module cannot be accessed.	<p>It is possible that port forwarding has been entered on the router with NAT function.</p> <p>Corrective measures:</p> <ul style="list-style-type: none"> • Remove the port forwarding from the router with NAT function. <hr/> <p>The firmware version of the inverter is not supported.</p> <p>Corrective measures:</p> <ul style="list-style-type: none"> • Check whether the firmware version of the inverter is supported (see Section 2.4, page 9). If the firmware version of the inverter is not supported, update the inverter firmware (see the Technical Description "Firmware Update with SD Card" at www.SMA-Solar.com).

8 Decommissioning

8.1 Removing the Speedwire/Webconnect Data Module

1. **⚠ DANGER**

Danger to life due to electric shock when opening the inverter

High voltages are present in the conductive components of the inverter. Touching live components results in death or serious injury.

- Disconnect the inverter from all voltage sources on the AC and DC sides and open it (see the inverter manual). Observe the waiting time to allow the capacitors to discharge.
2. Press the left-hand and right-hand lock hooks outwards and remove the ribbon cable plug from the center connector strip of the inverter.
 3. Loosen the screw of the display and flip the display up until it snaps into place.

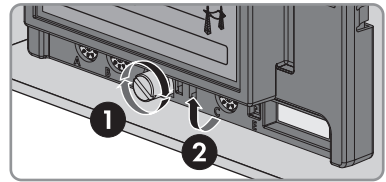

4. Remove the plugs of the network cable from the network ports of the Speedwire/Webconnect data module.
5. When using the supplied cable gland, perform the following steps at the enclosure opening of the inverter for the network cable:
 - Unscrew the swivel nut from the cable gland.
 - Unscrew and remove the counter nut of the cable gland.
 - Remove the cable gland and network cables from the inverter.
6. When using conduits, perform the following steps at the enclosure opening of the inverter for the network cables:
 - Remove the putty at the counter nut.
 - Unscrew the conduit from the adapter.
 - Loosen the counter nut of the adapter.
 - Remove the conduit from the adapter.
 - Remove the adapter.
 - Remove the network cables from the inverter and from the conduit.

7. Release the hexagon socket screw of the Speedwire/Webconnect data module (AF 3) and remove the module.

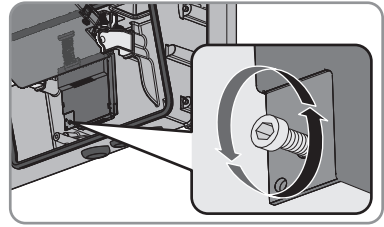

8. Flip the display down and fasten the display screw hand-tight.
9. Seal the enclosure opening of the inverter with the corresponding filler plug.
10. Close the inverter (see the inverter manual).

8.2 Packing the Product for Shipment

- Pack the product for shipping. Use the original packaging or packaging that is suitable for the weight and size of the product.

8.3 Disposing of the Product

- Dispose of the product in accordance with the locally applicable disposal regulations for electronic waste.

9 Technical Data

General Data

Mounting location	In the inverter
Voltage supply	Via the inverter

Mechanical Data

Width x height x depth	73 mm x 88 mm x 34 mm (2 ⁷ / ₈ in x 3 ⁷ / ₁₆ in x 1 ³ / ₈ in)
------------------------	--

Communication

Communication interface	Speedwire/Webconnect
Maximum cable length	100 m (328 ft)

Protocols

Data interface	SMA Modbus, SunSpec
----------------	---------------------

Ambient Conditions for Storage/Transport

Ambient temperature	-40°C to +85°C (-40°F to +185°F)
Relative humidity, non-condensing	10% to 100%

10 Contact

If you have technical problems with our products, please contact the SMA Service Line. We require the following information in order to provide you with the necessary assistance:

- Inverter:
 - Device type and serial number (see type label)
 - Firmware version (tap the inverter display twice or see Sunny Portal or Sunny Explorer)
- Speedwire/Webconnect data module:
 - Device type, serial number and hardware version (see type label)
 - Number of Speedwire/Webconnect data modules connected
- For Cluster Controller systems:
 - Serial number and firmware version of the Cluster Controller
- For Webconnect systems:
 - Name of your Sunny Portal system
 - PIC and RID of the Speedwire/Webconnect data module

Danmark	SMA Solar Technology AG	Belgien	SMA Benelux BVBA/SPRL
Deutschland	Niestetal	Belgique	Mechelen
Österreich	SMA Online Service Center:	België	+32 15 286 730
Schweiz	www.SMA-Service.com	Luxemburg	
	Sunny Boy, Sunny Mini Central, Sunny Tripower: +49 561 9522-1499	Luxembourg	
	Monitoring Systems (Kommunikationsprodukte): +49 561 9522-2499	Nederland	
	Fuel Save Controller (PV-Diesel-Hybridssysteme): +49 561 9522-3199	Česko	SMA Service Partner TERMS
	Sunny Island, Sunny Boy Storage, Sunny Backup, Hydro Boy: +49 561 9522-399	Magyarország	a.s.
	Sunny Central: +49 561 9522-299	Slovensko	+420 387 6 85 111
France	SMA France S.A.S. Lyon +33 472 22 97 00	Polska	SMA Polska +48 12 283 06 66
		Ελλάδα	SMA Hellas AE
		Κύπρος	Αθήνα +30 210 9856666

España Portugal	SMA Ibérica Tecnología Solar, S.L.U. Barcelona +34 935 63 50 99	United King- dom	SMA Solar UK Ltd. Milton Keynes +44 1908 304899
Bulgaria Italia România	SMA Italia S.r.l. Milano +39 02 8934-7299		
United Arab Emirates	SMA Middle East LLC Abu Dhabi +971 2234 6177	India	SMA Solar India Pvt. Ltd. Mumbai +91 22 61713888
ไทย	SMA Solar (Thailand) Co., Ltd. ประเทศไทย +66 2 670 6999	대한민국	SMA Technology Korea Co., Ltd. 서울 +82-2-520-2666
South Africa	SMA Solar Technology South Africa Pty Ltd. Cape Town 08600SUNNY (08600 78669) International: +27 (0)21 826 0600	Argentina Brasil Chile Perú	SMA South America SPA Santiago +562 2820 2101
Australia	SMA Australia Pty Ltd. Sydney Toll free for Australia: 1800 SMA AUS (1800 762 287) International: +61 2 9491 4200	Other countries	International SMA Service Line Niestetal Toll free worldwide: 00800 SMA SERVICE (+800 762 7378423)

